



# CE8MB-AHD

---

## OUTDOOR DOME CAMERA



# Overview

**CE8MB-AHD** is made of metal and built to survive in rugged and vandal susceptible environments. Vibration and thermal tested, the powerful camera is an excellent choice for various mobile environments. Utilizing the Sony CMOS imaging sensor, it provides outstanding image quality in both day and night lighting conditions. Besides, it also included an integrated Microphone which is able to captures clear audio.

## Main Features

- 2.0m Pixel CMOS
- 2.8\3.6mm Optional
- Easy To Assemble And Install
- Lockable Angle And Anti-vibration Design

## Dimension (Unit : mm)

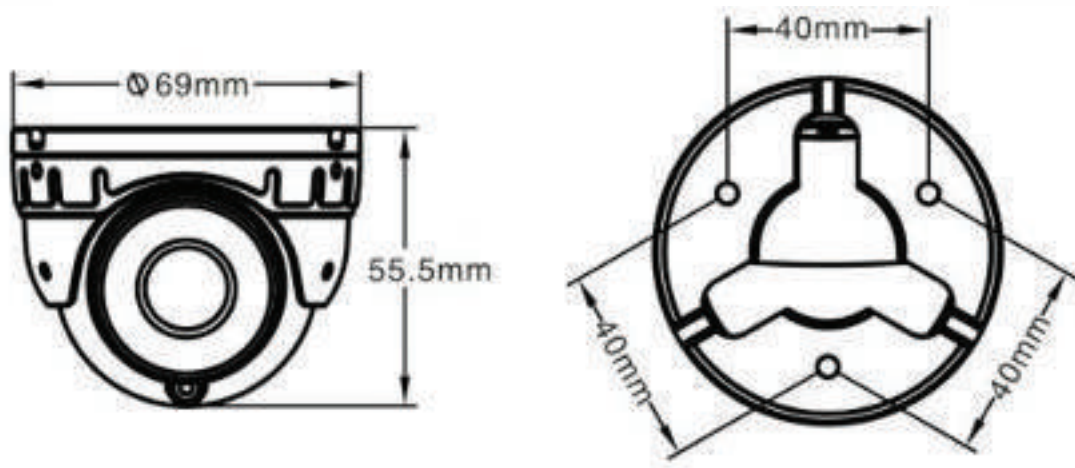

# Solution Reference

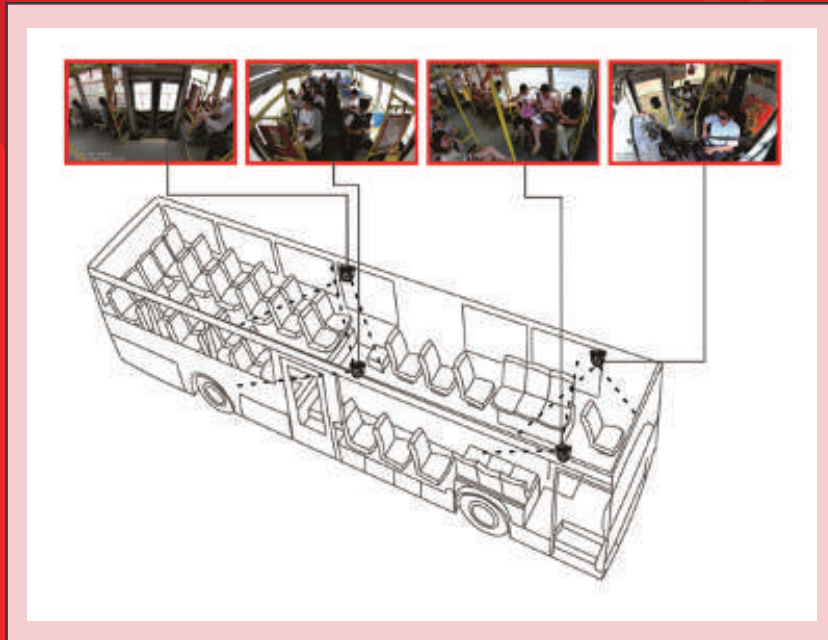

## Specification



<b>Model</b>	CE8MB-AHD
<b>CMOS</b>	1/2.9" 2M pixel CMOS
<b>Resolution</b>	1920H*1080V
<b>Format</b>	NTSC/PAL
<b>Minimum Illumination</b>	0.1Lux(IR off) /0Lux (IR on) F1.2
<b>IR distance</b>	5~8m
<b>S/N</b>	≥ 45dB
<b>Lens</b>	2.8, 3.6mm M12(Optional)
<b>FOV</b>	2.8mm H*V 90*47° 3.6mm H*V 81*42°
<b>Video Output</b>	1.0Vp-p AHD video output 75 Ω, 4pin DIN JACK
<b>Audio</b>	Built-in mic
<b>Power</b>	DC12V± 10%
<b>Consumption (Max.)</b>	120mA/DC12V ±5%
<b>Working Temperature</b>	-40°C ~+ 70°C
<b>Dimension</b>	69(W)*55.5(H)mm
<b>Weight</b>	About 168g



TNT SURVEILLANCE PTE LTD

📍 62, Ubi Road 1, Oxley Bizhub 2  
#10-20, Singapore 408734

☎ +65 6333 8687

🌐 [www.tnts.com.sg](http://www.tnts.com.sg)

▶ Enquiry: [info@tnts.com.sg](mailto:info@tnts.com.sg)